

Gepäckbrücke
Alurack

KAWASAKI Versys
ab Bj.2010

Artikel-Nr.:
4002.031.201 schwarz

Montage

Der Bausatz enthält folgende Teile:

Stück	Bestellnr.	Bezeichnung
1	799.997	Alu-Rack
1	799.904	Abdeckplatte für Rack
1	700007271	Rohrstrebe links
1	700007272	Rohrstrebe rechts
1	700002979	Adapterlasche links
1	700002980	Adapterlasche rechts
4	150.763	Inbusschrauben M6 x 20
4	150.809	U-Scheiben ø6,4
4	150.799	selbstsichernde Muttern M6
4	150.164	Viereck-Scheiben 20 x 20 x ø6,4
4	150.923	Linsenkopfschrauben M8x30
2	150.937	Linsenkopfschrauben M8x16
2	150.810	U-Scheiben ø8,4
2	150.995	U-Scheiben ø8,4 x17x3 mm
2	150.951	Karoseriescheiben ø8,4 xø24 x2mm
2	150.805	Sprengring ø8,4
4	151.069	Stahldistanzen ø14 x ø10x7 mm
1	330.300	Schriftzug Krauser



**Nach der Montage alle Verschraubungen auf festen Sitz kontrollieren!
Bitte beachten Sie unsere beigefügten Serviceinformationen.**

Als weiteres Zubehör lieferbar:

4002.031.201	Gepäckbrücke schwarz
3002.031.101	Motorschutzbügel
4002.031.131	C-Bow Softtaschenhalter



Krauser GmbH
An der Steinmauer 6
D-66955 Pirmasens

Tel.: +49 (0)6331 - 1453 - 250
Fax: +49 (0)6331 - 1453 - 260
eMail: vertrieb@krauser.de
www.krauser.de

Montage

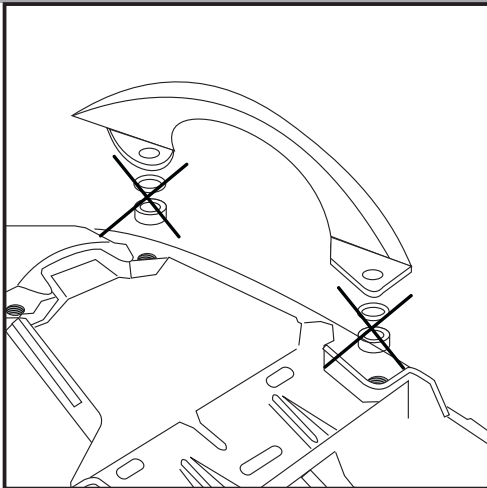

1

Vorbereitende Arbeiten:

Sitzbank und seitliche Verkleidungsteile (lackiert) demontieren.
Haltegriffe demontieren.

Die Blinker verbleiben in der Originalposition.

Die originalen Stahldistanzen aus den Haltepunkten der Haltegriffe demontieren, sie entfallen.
Ebenso entfallen die oberen Gummiringe

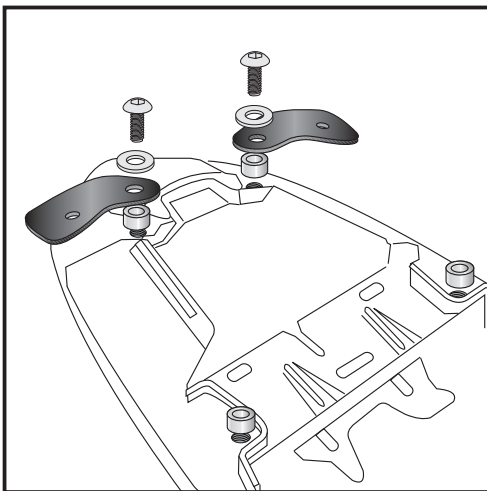

2

Montage der Adapterlaschen links und rechts:

Anstelle der Originaldistanzen die mitgelieferten Stahldistanzen $\varnothing 14 \times \varnothing 10 \times 7$ einsetzen.

Die Adapterlaschen werden an den hinteren Verschraubungspunkten mit den Linsenkopfschrauben M 8 x 30, Karoseriescheiben $\varnothing 8,4 \times \varnothing 24 \times 2$ mm verschraubt.

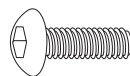

je 2x



4x

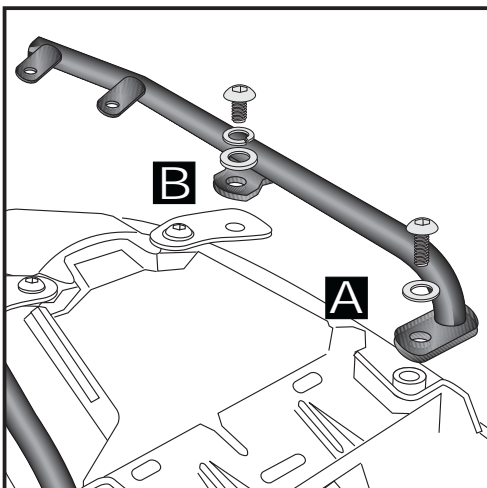

3

Montage der Rohrstreben links/rechts:

A Die Rohrstreben werden vorn mit den Linsenkopfschrauben M 8 x 30 und U-Scheiben $\varnothing 8,4$ verschraubt.

B Die hinteren Haltelaschen werden an dem Gewinde der Adapterlaschen mit den Linsenkopfschrauben 8 x 16, Spreng-ring $\varnothing 8,4$ und U-Scheiben $\varnothing 8,4 \times \varnothing 17 \times 3$ verschraubt.

Der Sprengring entfällt, wenn gleichzeitig der Lock-it-Kofferträger montiert wird.

A

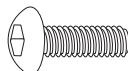

je 2x



B

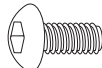

je 2x



Gepäckbrücke
Alurack

KAWASAKI Versys
ab Bj.2010

Artikel-Nr.:
4002.031.201 schwarz

KRAUSER[®]
MOTORRADGEPÄCKSYSTEME ■ BIKE BAGS

Montage

Montage des Alu-Rack:

Das Alu-Rack wird mit den Inbus-schrauben M6 x 20, Viereck-Scheiben 20 x 20 x ø6,4, U-Scheiben ø6,4 und selbstsichernden Muttern M6 an den deckungsgleich verlaufenden Bohrungen der Rohradapter verschrauben.

Anschließend die Kunststoffabdeckung des Alu-Racks montieren.

HINWEIS:

Alurack so montieren, dass sich die Sitzbank noch aufklappen läßt.

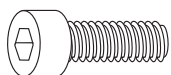

je 4x

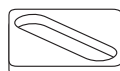

4

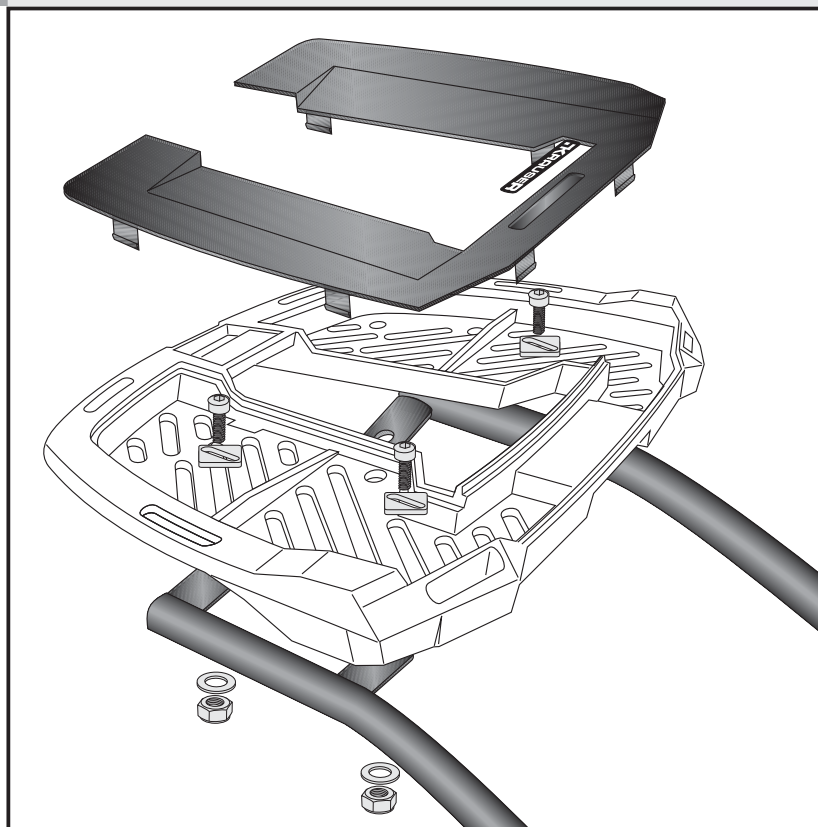

Rear carrier
Alurack

KAWASAKI Versys
from date of manufacture 2010

Item - No.:
4002.031.201 black

KRAUSER[®]
MOTORRADGEPÄCKSYSTEME ■ BIKE BAGS

Assembling instructions

The kit includes the following parts:

quant	item no.	description
1	799.997	alu-rack
1	799.904	plastic cover for rack
1	700007271	pipe strut left
1	700007272	pipe strut right
1	700002979	mounting strut left
1	700002980	mounting strut right
4	150.763	allen screw M6 x 20
4	150.809	washer ø6,4
4	150.799	self-lock nut M6
4	150.164	special washer 20 x 20 x ø6,4
4	150.923	fillister head screw M8x30
2	150.937	fillister head screw M8x16
2	150.810	washer ø8,4
2	150.995	washer ø8,4 x17x3 mm
2	150.951	body washer ø8,4 xø24 x 2 mm
2	150.805	lock ring ø8,4
4	151.069	steel spacer ø14 x ø10x7 mm
1	330.300	emblem Krauser



Control all screw connections after the assembling for tightness!
Please notice our enclosed service information.

Also available:

Rear rack	4002.031.201 black (Alurack)
Engine guard	3002.031.101
C-Bow	4002.031.131 (carrier for softluggage)



Krauser GmbH
An der Steinmauer 6

D-66955 Pirmasens

Tel.: +49 (0)6331 - 1453 - 250

Fax: +49 (0)6331 - 1453 - 260

eMail: vertrieb@krauser.de

www.krauser.de

Rear carrier
Alurack

KAWASAKI Versys
from date of manufacture 2010

Item - No.:
4002.031.201 black

KRAUSER[®]

MOTORRADGEPÄCKSYSTEME ■ BIKE BAGS

Assembling instructions

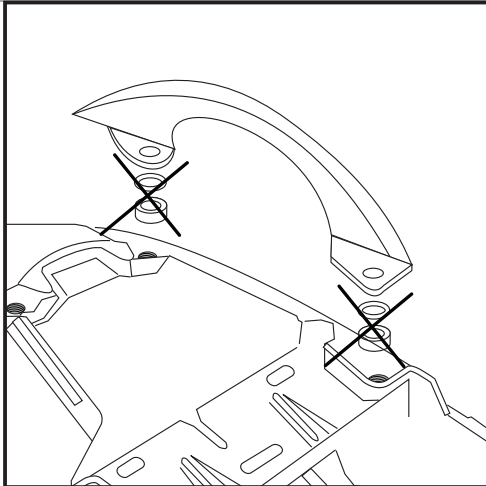

1

Preparing:

Unmount seat and handrails.
Unmount side sections of the rear cover.
Blinkers remain in their original position.

Not needed any more:
the original steel spacer from the handrails and rubber rings.

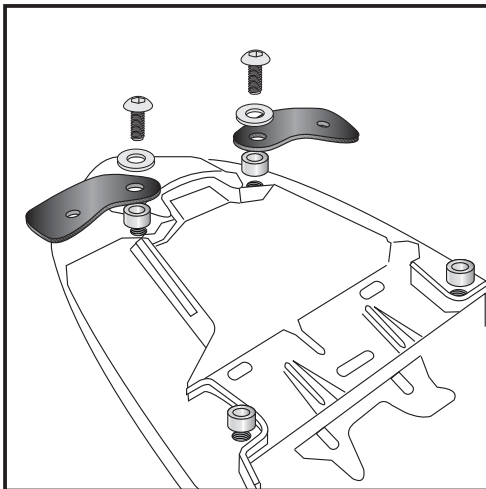

2

Fastening of the mounting strut left+right:

Use new steel spacer $\varnothing 14 \times \varnothing 10 \times 7$ instead of the original spacer.

The mounting struts will be fixed with filister head screw M 8 x 30
and body washer $\varnothing 8,4 \times \varnothing 24 \times 2$ mm.

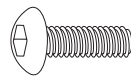

each 2x



4x

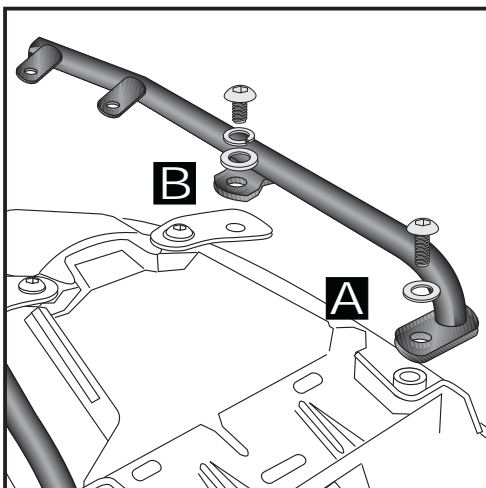

3

Fastening of the pipe strut left:

A at point A with filister head screw M 8 x 30 and washer $\varnothing 8,4$.

B at point B with filister head screw M8 x 16, lock ring $\varnothing 8,4$ and
washer $\varnothing 8,4 \times \varnothing 17 \times 3$.

Lock ring is not used if assembling with the side carrier.

A

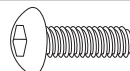

each 1x



B

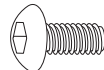

each 1x



Luggage ideas.

2

Rear carrier
Alurack

KAWASAKI Versys
from date of manufacture 2010

Item - No.:
4002.031.201 black

KRAUSER[®]

MOTORRADGEPÄCKSYSTEME ■ BIKE BAGS

Assembling instructions

Fastening of the alu-rack:
with allen screws M6x20,
special washers 20 x 20 x ø6,4,
washers ø6,4 and self-lock nuts M6.

Mount the plastic cover again.

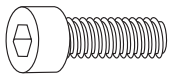

each
4x

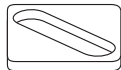

4

